

HBS

Hybrid Servo System

Advantages over Servo System

1. Continuous operation during rapid short-stroke movement due to fast positioning and response.
2. No gain tuning.
3. Maintains the stable holding position without oscillation after completing positioning.

Fast Response

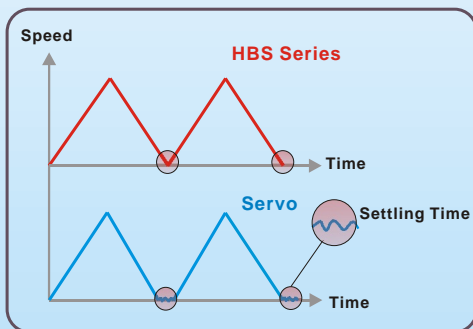

HBS series instantly synchronizes with command pulses providing fast positional response. HBS series is the optimum choice when zero-speed stability and rapid motions within a short distance are required. Traditional servo motor systems have a natural delay between the commanding input signals and the resultant motion because of the constant monitoring of the current position, necessitating in a waiting time until it settles, called settling time.

No Tuning

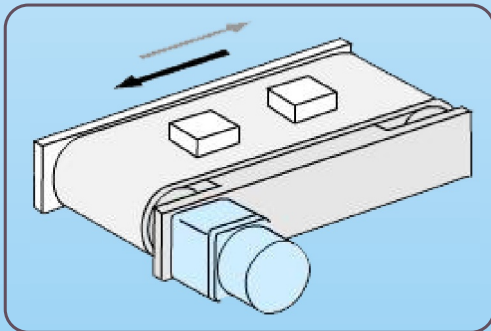

Conventional servo systems, to ensure machine performance, smoothness, positional error and low servo noise, require the adjustment of its servo's gains as an initial crucial step. HBS series employs the best characteristics of stepper and closed loop motion controls and algorithms to eliminate the need of tedious gain tuning required for servo systems. The HBS series employs the unique characteristics of the closed loop stepper motor control, eliminating these cumbersome steps and giving the engineer a high performance servo system without wasting setup time. HBS series is especially well suited for low stiffness loads (for example, a belt and pulley system) that some-time require conventional servo systems to inertia match with the added expense and bulk of a gearbox. HBS series also performs exceptionally, even under heavy loads and high speeds!

No Hunting



Traditional servo motor drives overshoot their position and try to correct by overshooting the opposite direction, especially in high gain applications. This is called null hunt and is especially prevalent in systems that the breakaway or static friction is significantly higher than the running friction. The cure is lowering the gain, which affects accuracy or using HBS Hybrid Servo System! HBS utilizes the unique characteristics of stepping motors and locks itself into the desired target position, eliminating Null Hunt. This feature is especially useful in applications such as nanotech manufacturing, semiconductor fabrication, vision systems and inkjet printing in which system oscillation and vibration could be a problem.

HBS

Hybrid Servo System

Advantages over Open-loop Control Stepper Drive

1. Reliable positioning without loss of synchronism.
2. The on-board high performance DSP (Digital Signal Processor) provides a performance improvement.
3. Higher efficiency from low heat generation is achieved by controlling the current flow to motor according to motor load.

Closed Loop System

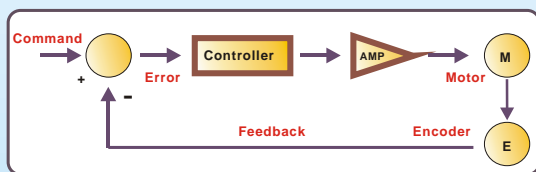

Most step-motor-based motion systems operate in open loop providing position control without feedback. When step motors move loads in open loop a potential loss of synchronism between commanded steps and actual steps may occur.

HBS series closed-loop stepper drive offers an alternative that remains cost-effective for applications requiring higher performance (higher speeds, better response time, more torque), added reliability, safety, or product quality assurance. An optical encoder is used to close the position, velocity and current loops in real time, just like servo systems - at a fraction the cost of a servo system

Smoothing & Accuracy

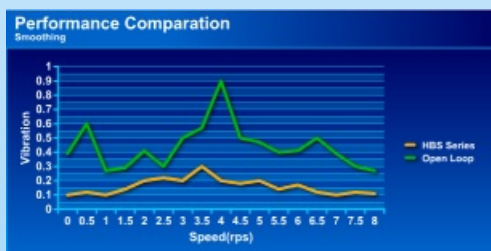

Unlike a conventional Micro step drive, the on-board high performance DSP (Digital Signal Processor) performs vector control and filtering, producing a smooth rotational control with minimum ripples.

High Torque & Low Heating

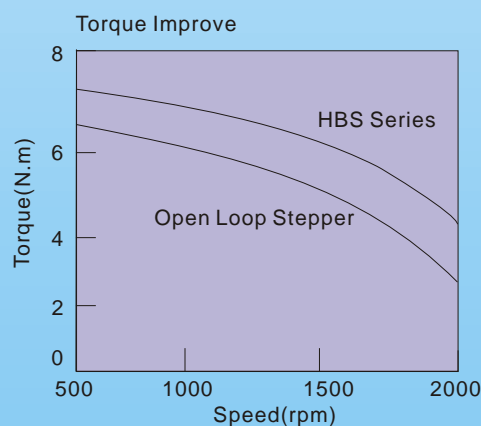

Torque improvement increases torque up to 30% at high speed, therefore they can drive a normal stepper motor to 3000 RPM or even higher, and significantly increase production efficiency.

Due to DSP precision current control algorithm, motor heat is 10–20 °C lower compare to a traditional stepper drive. Longer motor lifetime can be achieved, reducing maintenance cost. Drive heat is also 20% lower, offering higher drive stability and energy efficiency.

